

1

-13

D: 36

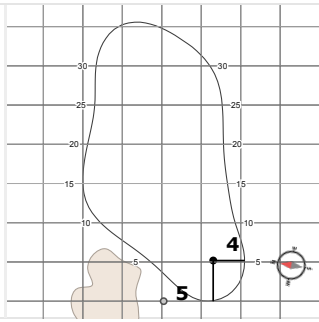

7

+6

D: 24

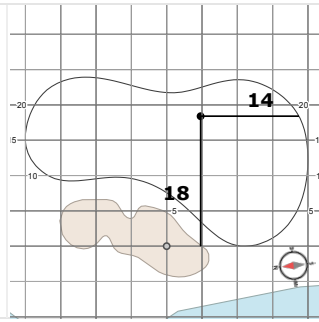

13

-8

D: 32

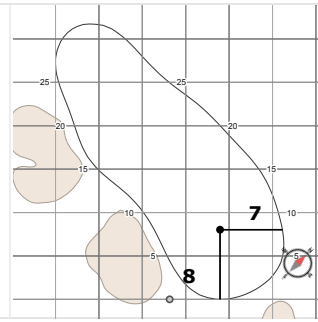

2

+3

D: 33

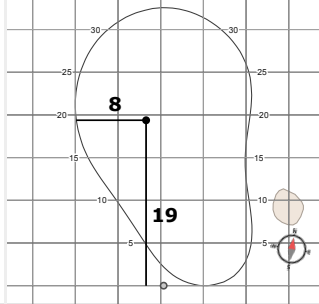

8

-5

D: 26

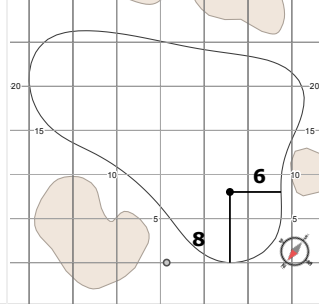

14

+6

D: 36

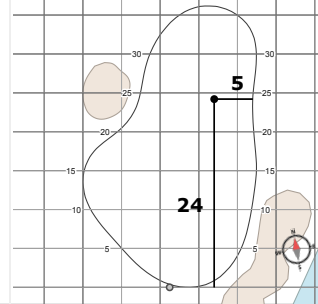

3

+14

D: 39

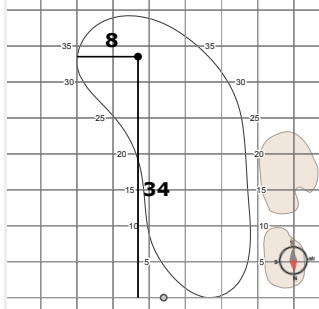

9

-5

D: 29

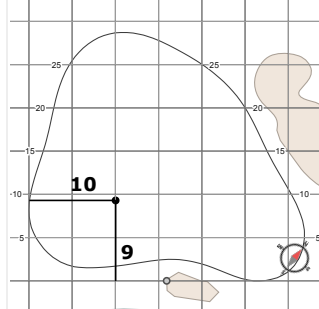

15

-5

D: 26

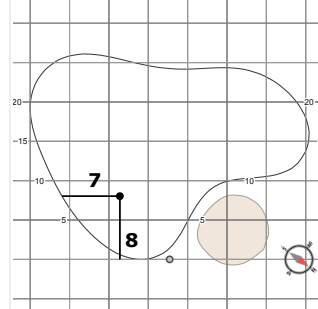

4

-10

D: 36

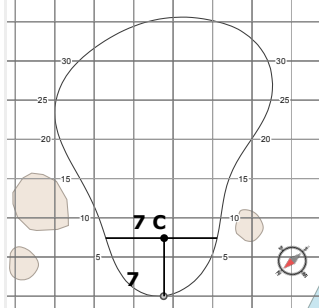

10

-12

D: 39

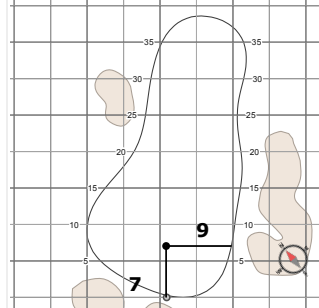

16

+9

D: 34

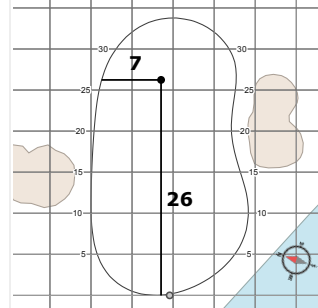

5

+10

D: 45

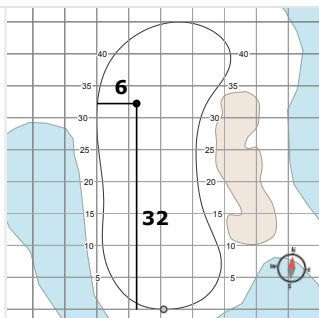

11

+4

D: 23

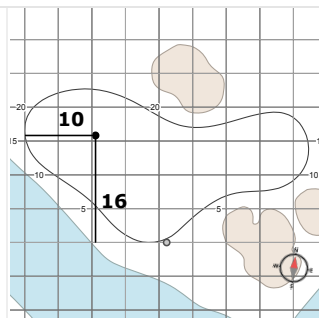

17

-7

D: 34

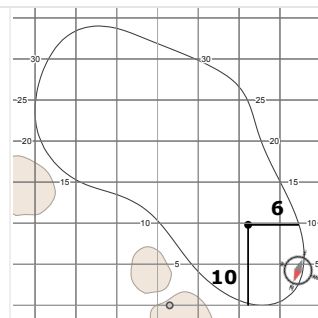

6

-7

D: 27

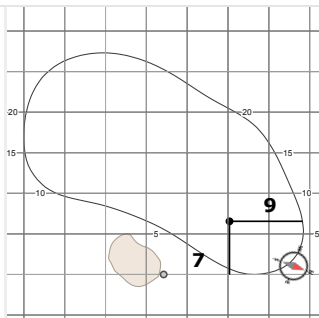

12

+10

D: 32

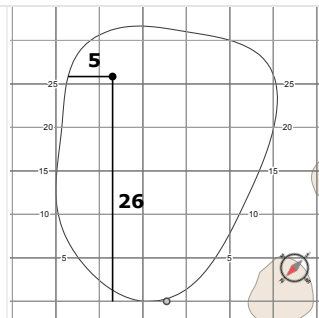

18

-2

D: 23

